

370

Technical Manual
V2014.01_EN

1	General	3
	Validity	3
	Safety	3
	Target Group	3
	Layout	3
	DT Swiss Manual Concept	4
	How to Use this Manual	4
	Cross References	4
	Warranty (Europe)	4
	Limited Equipment Warranty USA	5
1.1	General Maintenance Information	6
	Cleaning	6
	Tools	6
	Environmental Protection	6
	Disclaimer	6
2	Safety	7
3	Maintenance of the Hub	8
	Maintenance Intervals	8
	Hub Technologies	8
	Safety	8
3.1	Front Wheel [Pressed on Adapters]	9
	Removing the Adapters	10
	Dismounting the Bearings	11
	Cleaning the Parts	11
	Mounting the Bearings	12
	Mounting the Left Adapter	15
	Mounting the Right Adapter	16
3.2	Front Wheel [Inserted Adapters]	17
	Removing the Adapters	17
	Dismounting the Bearings	18
	Cleaning and Degreasing all Parts	18
	Mounting the Bearings	19
	Mounting the Adapters	20
3.3	Rear Wheel [Two Pawl System]	21
	Removing the Adapters, Rotor and Rotor Sealing	22
	Removing the Pawls, Spring and the Needle Cage	24
	Dismounting the Bearings	25

	Dismounting the Pawl Carrier	26
	Cleaning and Checking the Parts	27
	Mounting the Pawl Carrier	28
	Mounting the Bearing	30
	Mounting the Needle Cage, the Pawl and the Spring	32
	Mounting the Rotor and the Rotor Sealing	34
	Mounting the Adapters	35
3.4	Rear Wheel [Three Pawl System]	37
	Removing the Adapter, Rotor and Spacer	38
	Removing Pawls, Spring and Rotor Sealing	39
	Dismounting the Ring Nut	39
	Dismounting the Bearings	40
	Cleaning the Parts	41
	Mounting the Bearings and the Ring Nut	41
	Mounting the Pawls, the Spring and the Rotor Sealing	44
	Mounting the Spacer, the Rotor and the Adapters	45
4	Spare Parts	47
<hr/>		
4.1	370 100 mm/QR non disc	47
4.2	370 100 mm/QR disc brake	48
4.3	370 100 mm/15 mm.	49
4.4	370 110 mm/20 mm.	50
4.5	370 130 mm/QR.	51
4.6	370 135 mm/QR.	52
4.7	370 142 mm/12 mm disc brake	53

1 General

Validity

This manual describes the component shown on the front page and the footer. It is valid for the construction level of the component on the 2014-01-29. Deviations are possible and all items are subject to technical changes.

Safety

The safety instructions are classified as follows:

NOTE

...characterizes danger for goods.



CAUTION

...characterizes danger with a high risk, which causes mayhem if it is not being avoided.



DANGER

...characterizes immediate danger with a high risk, which causes death or mayhem if it is not being avoided.

Target Group

This manual is intended for the end user and dealers.

For experienced users, it offers the possibility to carry out small maintenance works on their own. If there are any doubts concerning the own skills, there should be contacted a DT Swiss service center.

Warranty will expire if works are not done properly.

Layout

The cover page and the footing are providing information about the type of product and manual as well as the version of the manual.

The backside provides a list of the DT Swiss service centers. A list of all DT Swiss service centers can be found at www.dtswiss.com.

This manual is intended for being printed as a A5 booklet. Only print this manual if electronical usage is not possible.

DT Swiss Manual Concept

The DT Swiss manuals are splitted into the following types of manuals:

- User Manual
Information for the end user of how to install and use the component.
- Technical Manual
Detailed information for the end user and the dealer of how to maintain the component, spare parts and technical data.

How to Use this Manual

The steps described in this manual must be carried out in the order they are shown. If steps are ignored or executed in a wrong order, the function of the component cannot be guaranteed.

Instructions are beginning with the table «Preparatory Steps» and ending with the table «Closing Steps». The instructions in these tables must be carried out.

Moving parts, threads, o-rings and sealings must be greased before assembling.

Cross References

In order to simplify the use of this manual, some text is edited as hypertext. Whenever the text is formatted blue and underlined, it is a reference to a chapter. If the text is formatted black and underlined, it is a reference to a figure. After clicking you will be automatically redirected to the target of the reference.

Example: Click here: [chap. 1, page 3](#) to jump to the beginning of this chapter.

Warranty (Europe)

In addition to the general guarantee required by law, DT Swiss AG based in Biel/Switzerland, provides a guarantee for 24 months from the date of purchase in accordance with European Directive 99/44/EC. DT Swiss AG shall reject any liability for both indirect damage caused by accidents and consequential damage.

Any contradictory or extended national rights of the purchaser are not affected by this warranty. Place of performance and jurisdiction is Biel/Switzerland. Swiss law shall apply.

Submit any warranty claims to your retailer or a DT Swiss service center. Any defects recognised by DT Swiss AG as a warranty claim will be repaired or replaced by a DT Swiss service center.

Warranty and guarantee claims can only be made by the original purchaser with a valid sales receipt.

There shall be no claim under the guarantee for:

- Normal wear and tear caused by use of the components
- Incorrect assembly
- Incorrect or non existent maintenance
- Incorrectly completed repairs
- Use of unsuitable products
- Modification of components
- Incorrect use or misuse
- Carelessness
- Leasing, commercial use or use in competitions
- Damage caused by accidents
- Delivery and transport damage
- Modification, defacing or removal of the serial number

Limited Equipment Warranty USA

DT Swiss LTD makes every effort to assure that its product meets high quality and durability standards and warrants to the original retail consumer/purchaser of our product that each product is free from defects in materials and workmanship as follows:

2 YEAR LIMITED WARRANTY ON THIS DT SWISS PRODUCT. This warranty does not apply to defects due directly or indirectly to misuse, abuse, negligence or accidents, repairs or alterations outside our facilities or to a lack of maintenance.

DT SWISS LTD LIMITS ALL IMPLIED WARRANTIES TO THE PERIOD OF TWO YEARS FROM THE DATE OF INITIAL PURCHASE AT RETAIL. EXCEPT AS STATED HEREIN, ANY IMPLIED WARRANTIES OF MERCHANTABILITY AND FITNESS ARE EXCLUDED. SOME STATES MAY NOT ALLOW LIMITATIONS ON HOW LONG THE IMPLIED WARRANTY LASTS, SO THE ABOVE LIMITATION MAY NOT APPLY TO YOU. DT SWISS LTD SHALL IN NO EVENT BE LIABLE FOR DEATH, INJURIES TO PEOPLE OR PROPERTY OR FOR INCIDENTAL, CONTINGENT, SPECIAL OR CONSEQUENTIAL DAMAGES ARISING FROM THE USE OF OUR PRODUCTS. SOME STATES MAY NOT ALLOW THE EXCLUSION OR LIMITATION OF INCIDENTAL OR CONSEQUENTIAL DAMAGES, SO THE ABOVE LIMITATION OR EXCLUSION MAY NOT APPLY TO YOU.

To take advantage of this warranty, the product or part must be returned for examination, postage prepaid, to the dealer where you bought the product or to a DT Swiss service center. Proof of purchase date and an explanation of the complaint must accompany the product. If our inspection discloses a defect, DT Swiss will either repair or replace the product or refund the purchase price, if we cannot readily and quickly provide a repair or replacement. DT Swiss will return repaired product or replacement at DT Swiss expense, but if it is determined there is no defect, or that the defect resulted from causes not within the scope of this warranty, then the user must bear the cost of shipping. This warranty gives you specific legal rights, and you may also have other rights which vary from state to state. Legal venue and place of performance is Biel (Switzerland). Swiss law shall apply. Subject to technical changes. Please keep the user manual and warranty for future use.

1.1 General Maintenance Information

Cleaning

For an optimal result of the maintenance works, every component that will be disassembled must be cleaned. There may only be used cleaners which do not damage the components. Especially the cleaning of o-rings and sealings requires mild cleaners. Always consider the instructions of the respective cleaner.

DT Swiss recommends the following cleaners:

- Motorex Rex
- Motorex Swissclean
- Motorex OPAL 2400, OPAL 3000, OPAL 5000

Use soap water or similar mild cleaners for external cleaning.

Tools

To ensure a damage-free mounting and dismounting of the components, only use the tools which are mentioned in this manual. The usage of differing tools is up to the user. If components are being damaged by the usage of differing tools, the user is liable.

Environmental Protection

Whenever possible, waste has to be avoided. Waste, especially carbon, lubricants, cleaners and any other fluids must be disposed in an environmentally compatible manner.

Only print this manual, if electrical usage is not possible.

Disclaimer

The operations described in this manual should only be done by professionals. The user is liable for any damage or consequential damage which is caused by wrong maintained or wrong installed components. If you have doubts, please contact a DT Swiss service center.

2 Safety



DANGER

Incorrect handling, installation, maintenance or servicing can lead to accidents causing severe injuries or death!

- Compliance with the following provisions is a prerequisite for accident-free use and faultless functioning.
- Assembly and maintenance of the component requires a basic knowledge of handling bicycle components. If in any doubt, consult your retailer.
- Components should only be used in accordance with their intended use, otherwise the user shall assume full responsibility.
- The component must be compatible with all parts of the bicycle.
- Only use original spare parts.
- The components must not be changed or modified.
- The component must not be used if it is damaged or there are any signs of damage. If in any doubt, consult a DT Swiss service center.



DANGER

Risk of death caused by incorrectly assembled or faulty wheels and hubs!

- Check that the wheel is connected correctly before each ride.
- Before every use, check the function of the rear wheel hub. Make sure that the freewheel and engagement connection function impeccably. Should there be any malfunction, the rear wheel hub must not be used.
- Check the wheel for damage before and after each ride.
- Regularly check the spoke tension, rotation and wear of the wheel.

3 Maintenance of the Hub

This chapter describes a big hub service. It includes:

- disassembly of the hub
- cleaning and greasing all parts
- assembly of new bearings and assembly of the hub

Maintenance Intervals

The following periodic maintenance and service works are recommended by DT Swiss:

Action	Interval
Maintenance of the hub <ul style="list-style-type: none">• normal operating conditions• extreme operating conditions (frequent rides in rain, mud, snow)	annually as required
Checking the hub for damages.	before and after each ride
Cleaning with a soft sponge and a appropriate cleaner. Do not use high pressure cleaners or aggressive cleaners.	after each ride

Hub Technologies

The following hub technologies are described in this manual:

- front wheel with pressed-on adapters (MTB with 15 mm and 20 mm dropout): [chap.3.1, p.9](#)
- front wheel with inserted adapters (MTB and ROAD with QR-dropouts): [chap.3.2, p.17](#)
- rear wheel with Two Pawl system (MTB and ROAD with QR-dropouts): [chap.3.3, p.21](#)
- rear wheel with Three Pawl system (MTB with 142/12 dropouts): [chap.3.4, p.37](#)

Safety



DANGER

Danger to life due to incorrect maintenance!

Wrong maintenance or assembly can lead to unpredictable errors.

- Maintenance must only be done by professionals.
- In case of any doubts, contact a DT Swiss service center.



CAUTION

Danger of injury due to false spare parts!

Usage of false spare parts can lead to unpredictable errors.

- Only use original spare parts or spare parts released by DT Swiss.

3.1 Front Wheel [Pressed on Adapters]

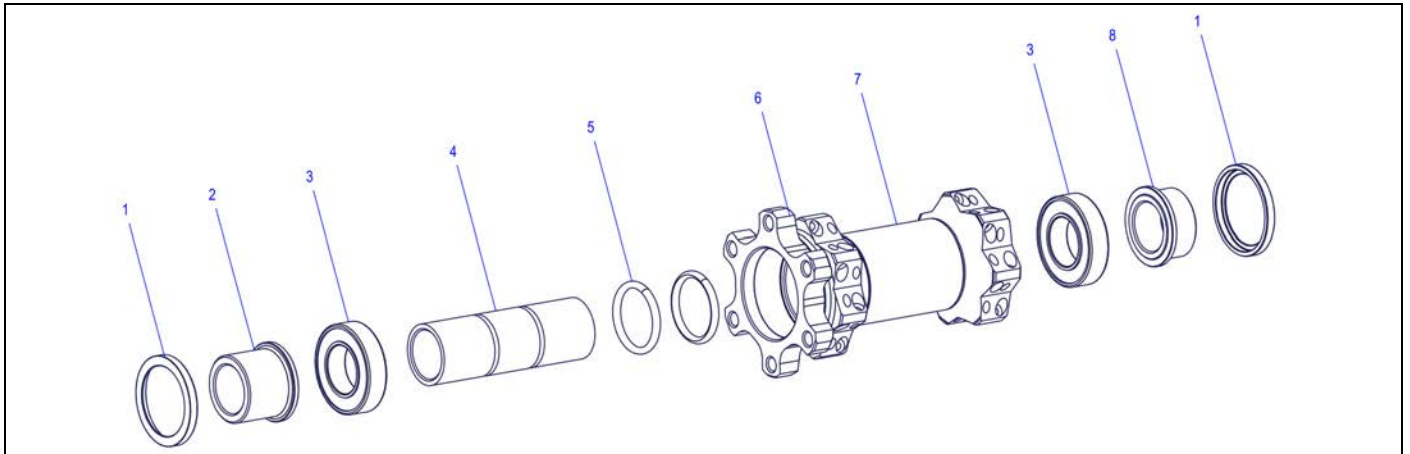

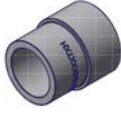





figure 3.1: Overview: front wheel with pressed on adapters

- | | | |
|----------------|-------------|-----------------|
| 1 cover | 4 spacer | 7 sticker |
| 2 adapter left | 5 o-ring | 8 adapter right |
| 3 ball bearing | 6 hub shell | 9 |

Preparatory Steps		Link
not required		
Required Material	Specification	Amount
mounting pin Ø15 mm	 HWTXXX00N5290S	1
mounting sleeve Ø28 mm		
mounting pin Ø20 mm	 HWTXXX00N5292S	1
mounting sleeve Ø37 mm		
installation tool	 HXTXXX00N5024S	2
nylon hammer		1
drift punch		1
universal grease		as required
ball bearing	see chap.4, p.47	2

Removing the Adapters

NOTE

Risk of damage of the adapters and the ball bearings!

The mounting pin must not touch the ball bearing while disassembling the adapters.

1. Plug the mounting pin into one of the adapters ([fig.3.1/2](#) or [8](#)).
2. Push the mounting pin downwards (see picture).

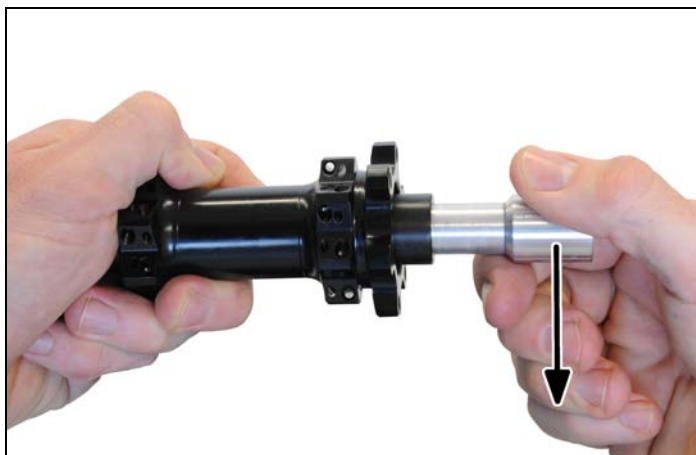

3. Remove the adapter ([fig.3.1/2](#) or [8](#)) and the cover ([fig.3.1/1](#)).



4. Repeat steps on the second adapter.

Dismounting the Bearings

1. Push the spacer (fig.3.1/4) beside and place a spin drift on the edge of the ball bearing (fig.3.1/3).
2. Slightly drive out the ball bearing opposite the disc-side.

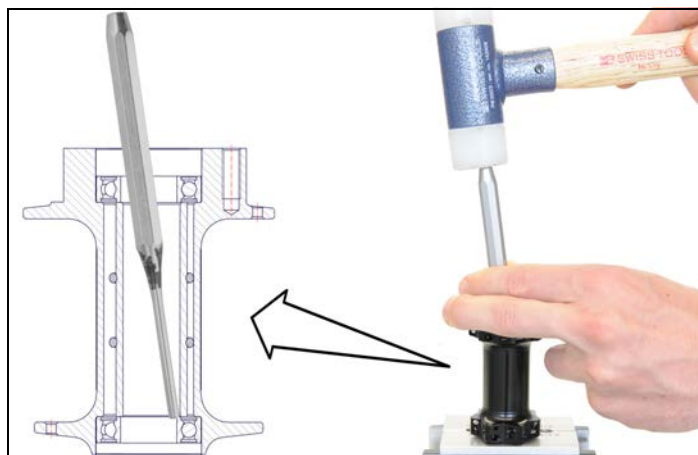

3. Turn the hub 180°.
4. Put the mounting pin with its big diameter onto the spacer.
5. Drive out the bearing (fig.3.1/3) on the disc-side.

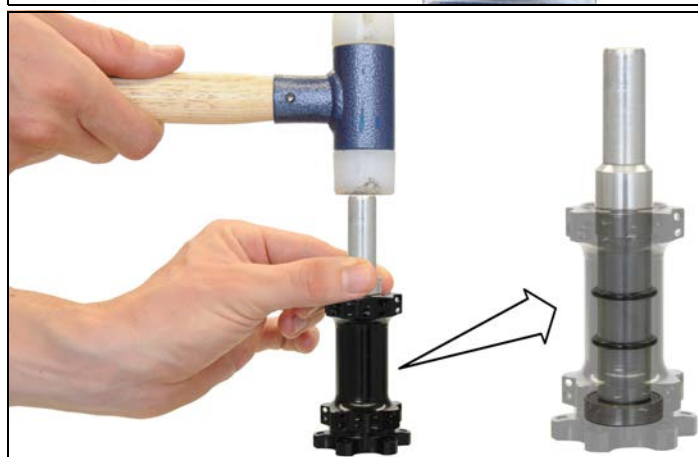

Cleaning the Parts

1. Clean all parts of the hub (see [Cleaning, p.6](#)).



Mounting the Bearings

1. Grease the bearing seats and the inner surface of the hub shell ([fig.3.1/6](#)).



2. Put a new bearing ([fig.3.1/3](#)) with the colored side outwards onto the bearing seat on the disc-side.



3. Put the installation tool into a vice.
4. Slide the non disc-side of the hub shell onto the tool.
5. Put the second installation tool onto the disc-side of the hub shell.



6. Drive in the bearing using a nylon hammer.



- 7. Turn the hub 180°.
- 8. Slide the spacer (fig.3.1/4) with the o-rings (fig.3.1/5) into the hub.



- 9. Put a new bearing (fig.3.1/3) with the colored side outwards onto the bearing seat.



- 10. Put the installation tool into a vice.
- 11. Slide the disc-side of the hub shell onto the tool.
- 12. Put the second installation tool onto the non disc-side of the hub shell.



- 13. Drive in the bearing (fig.3.1/3) using a nylon hammer.



14. Grease both bearings ([fig.3.1/3](#)).



Mounting the Left Adapter

1. Put the left adapter ([fig.3.1/2](#)) and the cover ([fig.3.1/1](#)) onto the hub.



2. Put the small diameter of the mounting sleeve onto the left adapter ([fig.3.1/2](#)).
3. Slide the mounting pin into the mounting sleeve.



4. Drive the cover ([fig.3.1/1](#)) onto the hub.



Mounting the Right Adapter

1. Put the right adapter ([fig.3.1/8](#)) and the cover ([fig.3.1/1](#)) onto the hub.

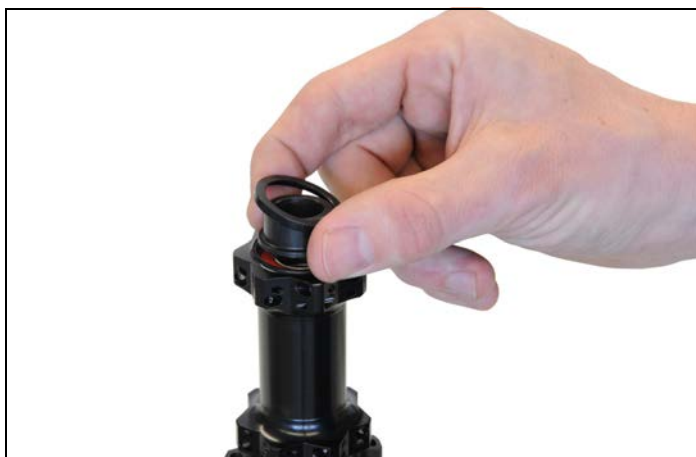

2. Put the big diameter of the mounting sleeve onto the right adapter ([fig.3.1/8](#)).
3. Slide the mounting pin into the mounting sleeve.



4. Drive the cover ([fig.3.1/1](#)) onto the hub.



Closing Steps

not required

Link

3.2 Front Wheel [Inserted Adapters]

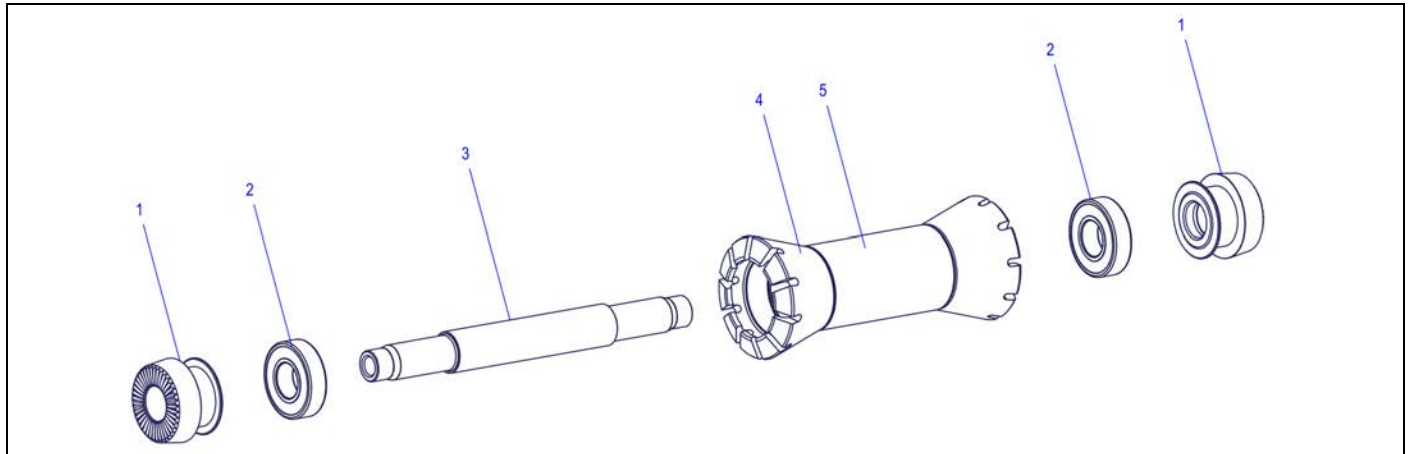



figure 3.2: Overview: front wheel with inserted adapters

- | | | |
|----------------|-------------|-----------|
| 1 adapter | 3 spacer | 5 sticker |
| 2 ball bearing | 4 hub shell | |

Preparatory Steps		Link
not required		
Required Material	Specification	Amount
short installation tool	 HXTXXX00N5023S	2
nylon hammer		1
universal grease		as required
ball bearing	see chap.4, p.47	2

Removing the Adapters

1. Remove the adapters ([fig.3.2/1](#)) by hand.



Dismounting the Bearings

1. Hit the axle (fig.3.2/3) with a nylon hammer and drive out the first bearing (fig.3.2/2).



2. Take the bearing (fig.3.2/2) from the axle (fig.3.2/3).



3. Slide the axle (fig.3.2/3) through the second bearing (fig.3.2/2).
4. Repeat steps to drive out the second bearing.

Cleaning and Degreasing all Parts

1. Clean all parts of the hub (see [Cleaning, p.6](#)).



Mounting the Bearings

1. Grease the bearing seats and the inner surface of the hub shell ([fig.3.2/4](#)).



2. Slide the axle ([fig.3.2/3](#)) into the installation tool.



3. Slide the hub shell ([fig.3.2/4](#)) onto the installation tool and the axle ([fig.3.2/3](#)).
4. Put a new bearing with the colored side outwards onto the axle and the hub shell.



5. Put the second installation tool onto the bearing ([fig.3.2/2](#)) and drive in the bearing using a nylon hammer.



6. Turn the hub 180° and repeat steps to drive in the second bearing.
7. Check the play of the hub. Therefore hold the axle and move the hub axial.
 - > The hub must not have play.
8. If there is play, drive in the bearing. If you are using a disc-brake-hub, drive in the bearing on the disc-side first.
9. Check the running of the bearings. Therefore hold the axle and turn the hub.
 - > The hub must turn smoothly.
10. If the hub turns stiff, slightly loosen the bearings by hitting the axle with slight hammer strokes. If you are using disc brake hubs, first loosen the bearing on the non disc-side.

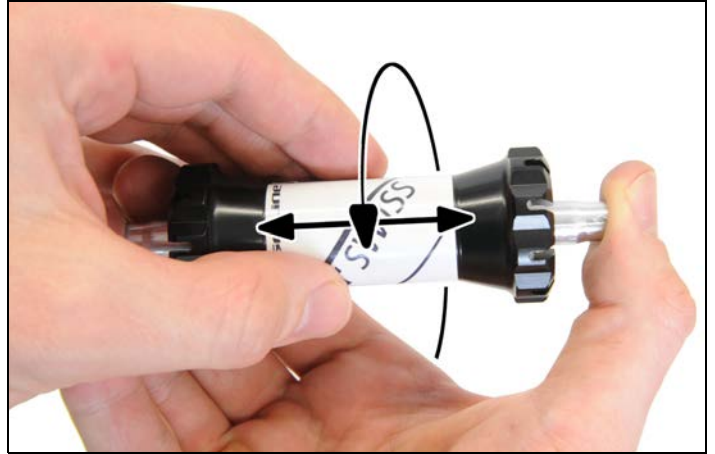

Mounting the Adapters

1. Grease the bearings and the inner surface of both adapters ([fig.3.2/1](#)).



2. Put the adapters ([fig.3.2/1](#)) onto the hub by hand.



Closing Steps

not required

Link

3.3 Rear Wheel [Two Pawl System]

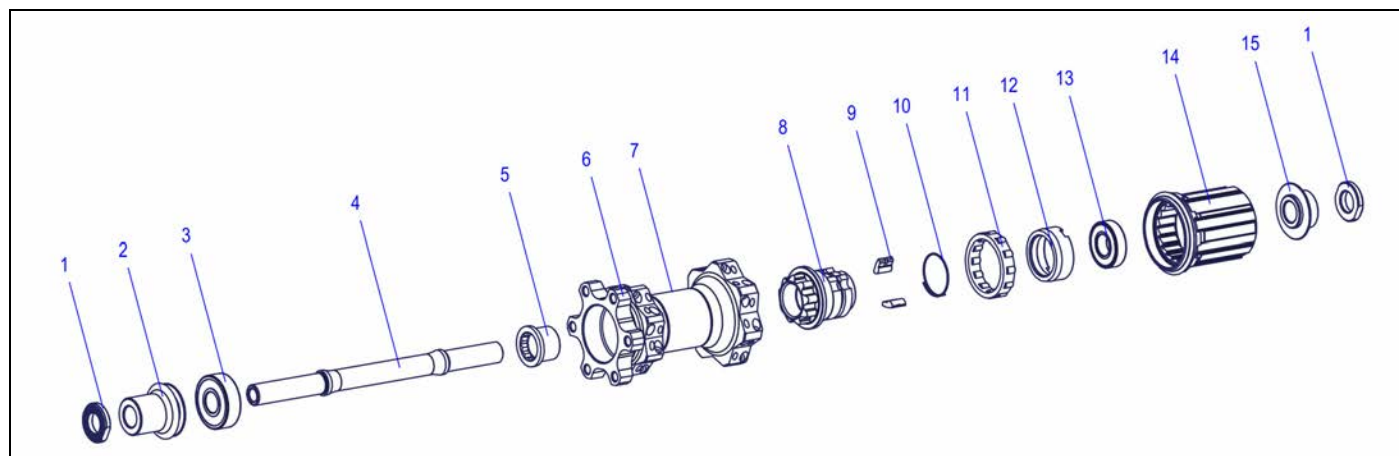





figure 3.3: Overview Two Pawl System

1 knurled disc	6 hub shell	11 needle cage
2 adapter right	7 sticker	12 bearing shell
3 ball bearing	8 pawl carrier	13 ball bearing
4 axle	9 pawl	14 rotor
5 screw fitting for pawl carrier	10 spring for pawl carrier	15 adapter left

Preparatory Steps		Link
Remove the cassette.		see instructions of the manufacturer
Required Material	Specification	Amount
short installation tool	 HXTXXX00N5016S	1
long installation tool	 HXTXXX00N5017S	1
wrench for bearing shell	 HXTXXX00N5030S	1
axle holder	 HXTXXX00N5001S	1
wrench	17 mm	1
wrench	27 mm	1
Allen key	12 mm	1
nylon hammer		1
forceps		1
universal grease		as required

Required Material	Specification	Amount
service kit ONYX/CERIT	includes spring for pawl carrier, two pawls, universal grease, see chap.4, p.47	as required
needle cage kit	includes needle cage and 12 needles, see chap.4, p.47	as required
spring for pawl carrier	see chap.4, p.47	1
ball bearing drive side	see chap.4, p.47	1
ball bearing non drive side	see chap.4, p.47	1

Removing the Adapters, Rotor and Rotor Sealing

1. Clamp the axle opposite to the rotor-side into the axle holder.
2. Unscrew the knurled disc ([fig.3.3/1](#)) on the rotor side using a 17 mm wrench.



3. Remove the knurled disc ([fig.3.3/1](#)) and the adapter ([fig.3.3/15](#)).

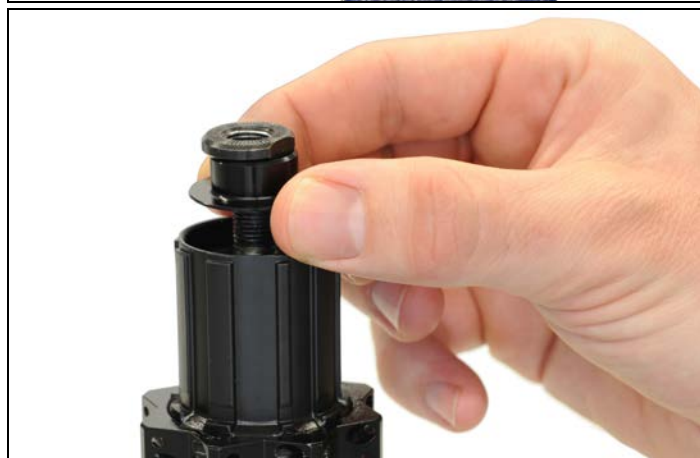

4. Carefully slide the rotor ([fig.3.3/14](#)) off the hub.



- 5. Clamp the axle on the rotor-side into the axle holder.
- 6. Unscrew the knurled disc (fig.3.3/1) using a 17 mm wrench.



- 7. Remove the knurled disc (fig.3.3/1) and the adapter (fig.3.3/15).



- 8. Remove the rotor sealing.



Removing the Pawls, Spring and the Needle Cage

1. Push the spring (fig.3.3/10) out of the groove using a flat screwdriver.

Caution: If you remove the spring, it has to be replaced by a new one.

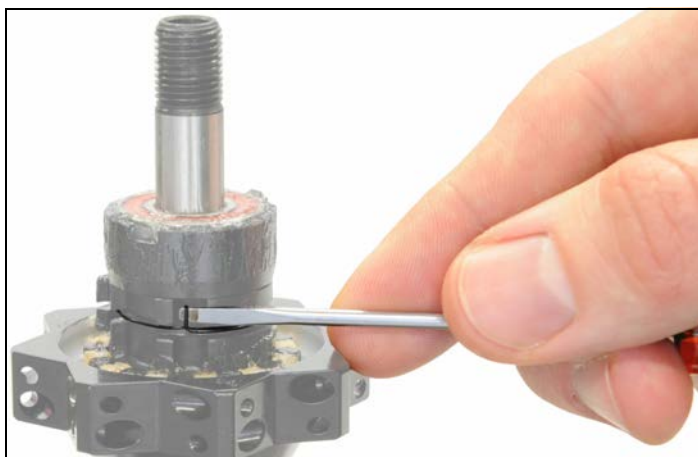

2. Slide the spring (fig.3.3/10) upwards and remove it.



3. Remove both pawls (fig.3.3/9).



4. Slide the needle cage (fig.3.3/11) upwards and remove it.



Dismounting the Bearings

1. Dismount the bearing (fig.3.3/3) opposite to the drive side by hitting the axle (fig.3.3/4) with a nylon hammer.



2. Remove the bearing (fig.3.3/3) from the axle (fig.3.3/4).



3. Slide the axle (fig.3.3/4) through the bearing (fig.3.3/13) on the drive side.
4. Drive out the bearing using a nylon hammer.



5. Remove the bearing (fig.3.3/13) from the axle (fig.3.3/4).



Dismounting the Pawl Carrier



The pawl (fig.3.3/5) carrier and the bearing shell (fig.3.3/12) must only be dismounted, if they are damaged!

1. Clamp the long installation tool into the vice.
2. Put the axle (fig.3.3/4) into the installation tool.
3. Slide the hub shell (fig.3.3/6) onto the installation tool and the axle.
4. Put the wrench for the bearing shell (fig.3.3/12) onto the bearing shell.



5. Unscrew the bearing shell (fig.3.3/12) using a 27 mm wrench.
Caution: left-hand thread!
6. Remove the hub, axle and installation tool from the vice.



The screw connection of the pawl carrier gets tightened while pedaling. Because of this it might be very hard to loose the pawl carrier. It is recommended to loosen the pawl carrier only when the wheel is complete.

7. Put a 12 mm Allen key into a vice.
8. Put the hub body (fig.3.3/6) onto the Allen key.
9. Turn the wheel anti clockwise and loosen the pawl carrier (fig.3.3/5).
10. Put the hub and the Allen key out of the vice.



- 11.** Remove the pawl carrier (fig.3.3/8) and the screw fitting (fig.3.3/5).



Cleaning and Checking the Parts

1. Clean all parts of the hub (see [Cleaning, p.6](#)).
2. Check the needle cage, the pawls and the spring for damages. Replace the parts if necessary.



3. Clean the rotor (fig.3.3/14) with a mild cleaner.
4. Check the rotor for damages. Grooves from the cassette are no damages. These are normal signs of usage.
5. Clean the rotor sealing with a mild cleaner.
6. Check the sealing for damages and replace if necessary.



7. Remove bad notches from the rotor (fig.3.3/14) using a file.
8. Clean the rotor. Metal filings must be removed completely.



Mounting the Pawl Carrier

1. Grease the bearing seats and the inner surface of the hub shell.



2. Put a 12 mm Allen key into a vice.
3. Put the screw fitting (fig.3.3/5) onto the Allen key.
4. Put the hub shell (fig.3.3/6) onto the screw fitting.



5. Put the pawl carrier (fig.3.3/8) into the hub shell (fig.3.3/6).



6. Turn the wheel (or the hub shell) clockwise and tighten the screw fitting with a min. torque of 60 Nm.
7. Remove the hub and the Allen key from the vice.



- 8. Put the long installation tool into the vice.
- 9. Put the long side of the axle (fig.3.3/4) into the installation tool.
- 10. Slide the hub shell onto the tool and the axle.
- 11. Screw the bearing shell (fig.3.3/12) onto the pawl carrier (fig.3.3/8) by hand.



- 12. Put the wrench for the bearing shell onto the bearing shell (fig.3.3/12).



- 13. Screw on the bearing shell using a 27 mm wrench. Caution: Left-hand thread.



Mounting the Bearing

1. Put a new bearing (fig.3.3/13) with its colored side outwards onto the bearing shell (fig.3.3/12).



2. Put the short installation tool onto the bearing (fig.3.3/13).
3. Drive in the bearing using a nylon hammer.



4. Take the axle (fig.3.3/4) out of the hub, turn it 180° and put it back into the hub.
5. Put the drive side of the hub onto the long installation tool.



6. Put a new bearing (fig.3.3/3) with its colored side outwards onto the axle.



7. Put the short installation tool onto the bearing (fig.3.3/3).
8. Drive in the bearing using a nylon hammer.



9. Check the play of the hub. Therefore hold the axle and move the hub axial.
 - > The hub must not have play.
10. If there is play, drive in the bearing.
 - If you are using a disc-brake-hub, drive in the bearing on the disc-side first.
11. Check the running of the bearings. Therefore hold the axle and turn the hub.
 - > The hub must turn smoothly.
12. If the hub turns stiff, slightly loosen the bearings by hitting the axle with slight hammer strokes.
 - If you are using disc brake hubs, loosen the bearing on the non disc-side.

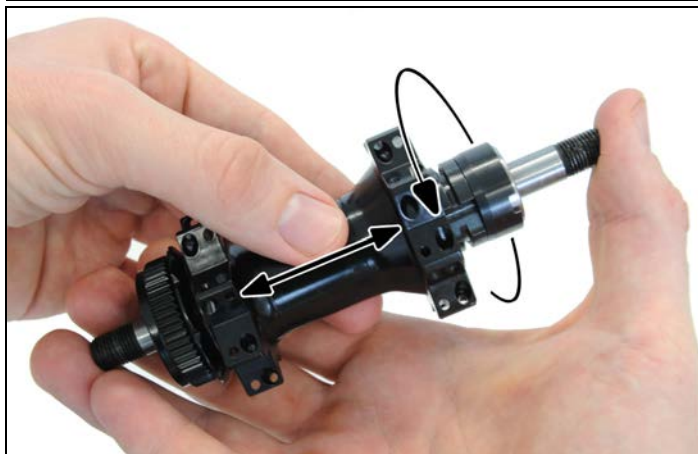

Mounting the Needle Cage, the Pawl and the Spring

1. Grease the needle cage (fig.3.3/11) and the needles using universal grease.

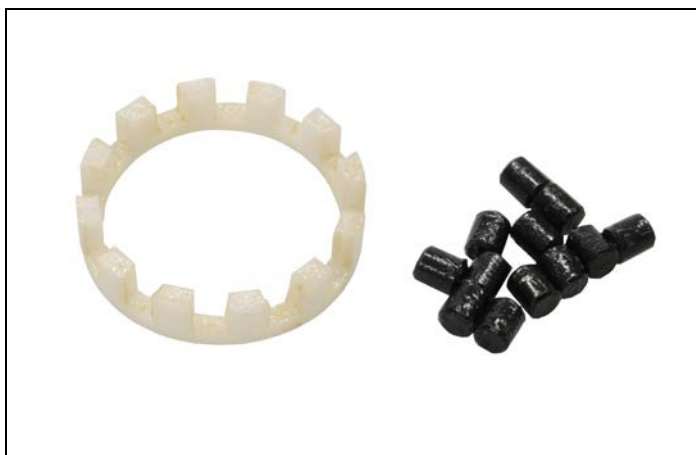

2. Grease the bearing shell (fig.3.3/12), the inner surface of the hub shell, the axle and the thread using universal grease.



3. Slide the needle cage (fig.3.3/11) onto the hub and attach the needles using forceps (or s.th. similar).
4. Check if all needles are attached correctly inside the needle cage.



5. Attach both pawls (fig.3.3/9). Grease the pawls generous. This way, the pawls stuck in the correct position.



6. Slide a new spring (fig.3.3/10) onto the bearing shell (fig.3.3/12).
The spring must not be damaged while mounting!



7. Slide the spring (fig.3.3/10) onto the pawls (fig.3.3/9).
8. Check, if the spring sits inside the groove over the complete circumference.
9. Check, if the pawls can be moved.

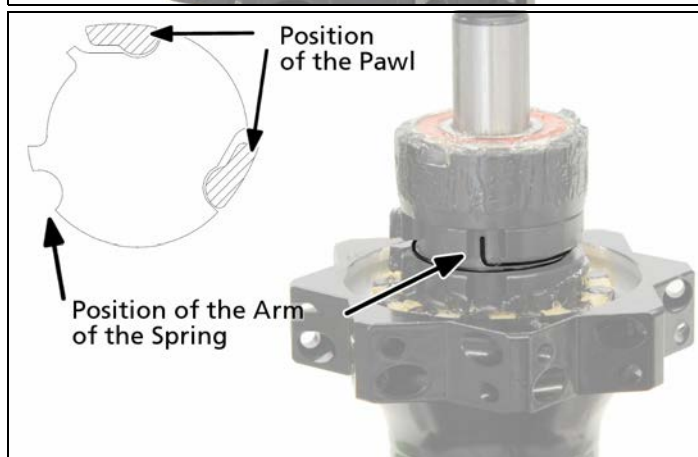

10. Grease the pawls (fig.3.3/9) slightly using universal grease.



11. Grease the bearing generously.



Mounting the Rotor and the Rotor Sealing

1. Grease the rotor sealing using universal grease.



2. Mount the rotor sealing.
The sealing lip must face to the rotor (see picture).
3. Fill the seat of the needle cage with universal grease.



4. Slide the rotor ([fig.3.3/14](#)) onto the hub while performing a rotary motion.
5. Check if the rotor can be turned easily and if the pawls lock.



Mounting the Adapters

1. Grease the bearings and the inner surface of the adapters.



2. Put the right adapter (fig.3.3/15) onto the drive side.



3. Put the left adapter (fig.3.3/2) on the non drive-side of the hub.



4. Attach both knurled discs (fig.3.3/1) and tighten them by hand.
5. Put the knurled disc on the non drive side into a vice. Ensure that only the knurled disc is clamped.
6. Tighten the knurled disc with a torque of 17 Nm using a 17 mm wrench.
7. Take the hub out of the vice.
8. Check both knurled discs for the correct torque.



Closing Steps

Link

Mount the cassette

see instructions of the manufacturer

3.4 Rear Wheel [Three Pawl System]

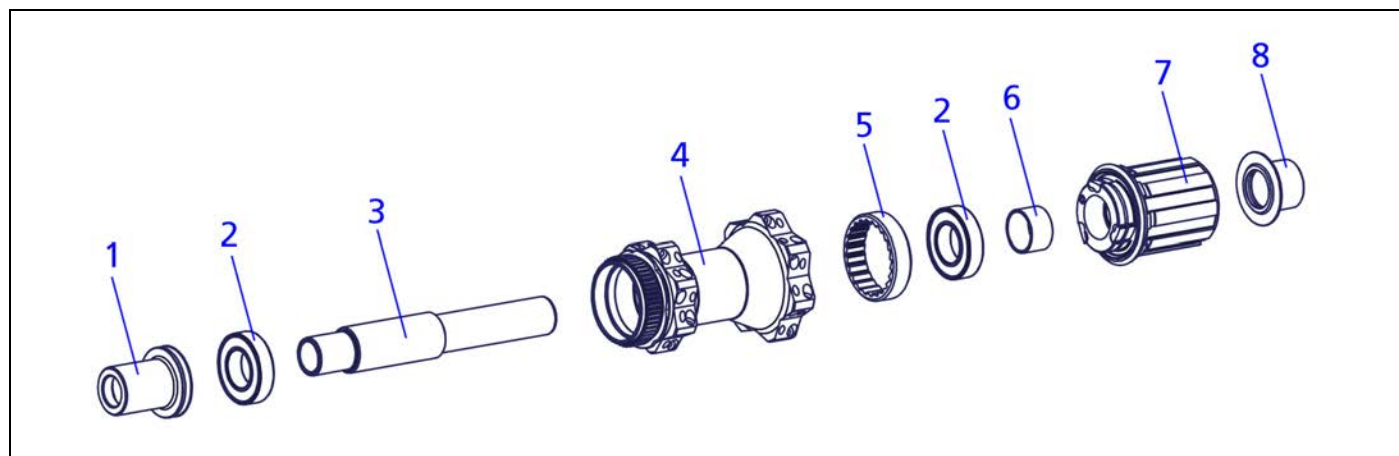



figure 3.4: Overview Three Pawl System

1 adapter left	4 hub shell	7 rotor
2 ball bearing	5 ring nut	8 adapter right
3 axle	6 spacer	

Preparatory Steps		Link
Remove cassette.		see instructions of the manufacturer
Required Material	Specification	Amount
short installation tool	 HXTXXX00N5024S	2
tool for ring nut	 HXTXXX00N5266S	1
nylon hammer		1
screwdriver		1
universal grease		as required
ball bearing	see chap.4, p.47	2
service kit 3 pawl system	see chap.4, p.47	as required

NOTE

Risk of damage of the adapters!

To avoid damages, only use grind clamping jaws, aluminium clamping jaws or special tools to clamp the adapters.

Removing the Adapter, Rotor and Spacer

1. Clamp the right adapter (fig.3.4/8) into a vice.
2. Pull off the wheel, respectively the hub. Take care that the rotor does not fall off.
3. Clamp the left adapter (fig.3.4/1) into a vice.
4. Pull off the wheel, respectively the hub.



5. Pull the rotor (fig.3.4/7) off the hub.



6. Pull the spacer (fig.3.4/6) off the axle.



Removing Pawls, Spring and Rotor Sealing

1. Remove the spring using a small, flat screwdriver.
2. Remove the pawls.



3. Remove the rotor sealing.
4. Check the sealing. Change a broken sealing.



Dismounting the Ring Nut



The ring nut has only to be replaced, if it is damaged.
The bearing on the drive side can also be changed when the ring nut is still mounted.



The ring nut gets tightened while pedaling. Because of this it might be very hard to loose the ring nut. It is recommended to loosen the ring nut only when the wheel is complete.

1. Put the tool for the ring nut in the clamp in its high position.
2. Put the drive side of the hub onto the tool.
3. Turn the wheel, respectively the hub anti clock-wise.



4. Remove the ring nut from the tool.
5. Remove the tool from the vice.



Dismounting the Bearings

1. Drive out the bearing on the disc-side by hitting the axle with a nylon hammer.



2. Remove the bearing from the axle.



3. Turn the axle 180° and put it through the hub and the bearing on the drive side.
4. Drive out the bearing on the drive side,



5. Remove the bearing from the axle.



Cleaning the Parts

1. Clean all parts of the hub (see [Cleaning, p.6](#)).



Mounting the Bearings and the Ring Nut

1. Grease the bearing seats and the thread for the ring nut.



2. Put the short installation tool into the vice.
3. Slide the bearing with the colored side outwards onto the axle.
4. Slide the axle and the bearing into the installation tool.



5. Put the drive side of the hub onto the installation tool.
6. Slide the long installation tool onto the non drive side of the hub.



7. Hit the long installation tool using a nylon hammer.
8. Remove the long installation tool from the hub.
9. Remove the hub from the short installation tool.
10. Remove the short installation tool from the vice.



11. Put the tool for the star nut in the lower position into the vice.
12. Put the star nut onto the tool.



- 13. Put the hub shell onto the ring nut.
- 14. Turn the hub shell clockwise and tighten the star nut handtight.



- 15. Remove the hub from the tool.
- 16. Remove the tool from the vice, turn it 90° and put it back into the vice.
- 17. Put the hub onto the tool.



- 18. Put a new bearing with the colored side outwards onto the non drive side.



- 19. Drive in the bearing using a plastic hammer.



- 20.** Check the play of the hub. Therefore hold the axle and move the hub axial.
 - > The hub must not have play.
- 21.** If there is play, drive in the bearing. If you are using a disc-brake-hub, drive in the bearing on the disc-side first.
- 22.** Check the running of the bearings. Therefore hold the axle and turn the hub.
 - > The hub must turn smoothly.
- 23.** If the hub turns stiff, slightly loosen the bearings by hitting the axle with slight hammer strokes. If you are using disc brake hubs, loosen the bearing on the non disc-side.

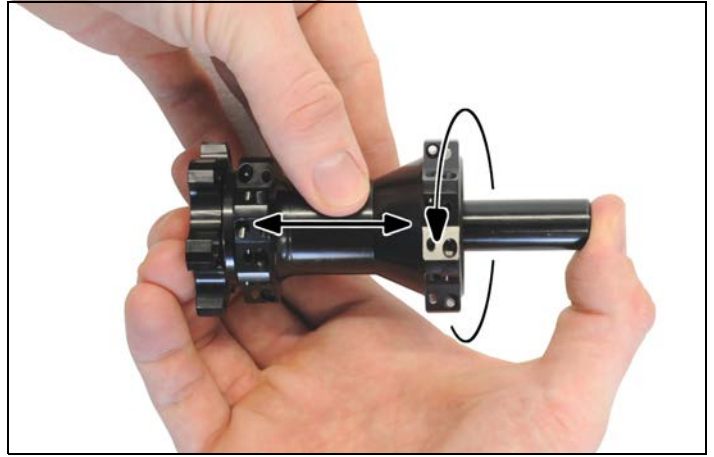

Mounting the Pawls, the Spring and the Rotor Sealing

- 1.** Mount the rotor sealing.



- 2.** Slightly grease the rotor and the rotor sealing.



- 3.** Mount the pawls. Grease the pawls generous. This way, the pawls stuck in the correct position.

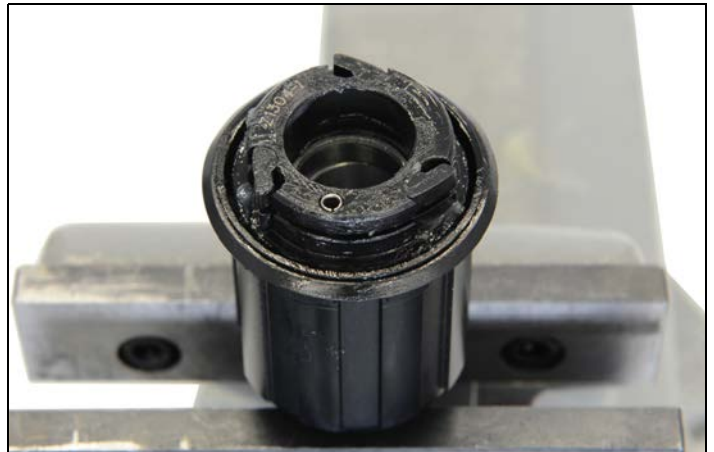

4. Mount the spring.
The open end of the spring must be positioned at the pin.



5. Slightly grease the pawls with universal grease.

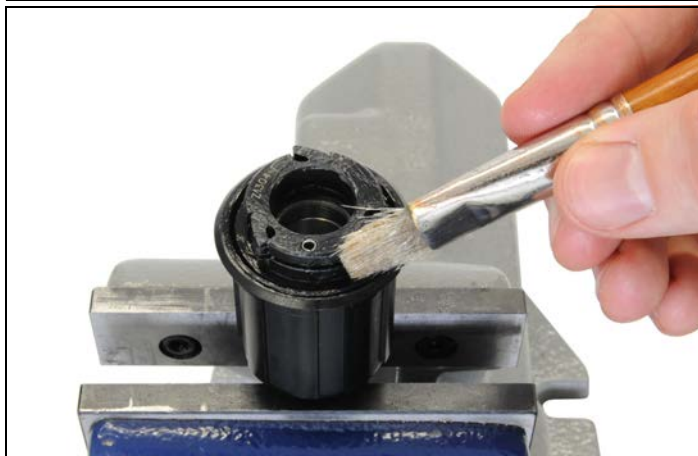

Mounting the Spacer, the Rotor and the Adapters

1. Grease the bearing and the axle.



2. Slide the spacer (fig.3.4/6) onto the axle.



3. Slide the rotor (fig.3.4/7) onto the hub while performing a rotary motion.
4. Check if the rotor can be turned easily and if the pawls lock.



5. Grease the bearings and the inner surface of both adapters (fig.3.4/1, 8).



6. Put on both adapters (fig.3.4/1, 8) and push them in by hand.

Caution: The shorter adapter must be attached on the drive side.



Closing Steps

Mount the cassette.

Link

see instructions of the manufacturer

4 Spare Parts

NOTE

Different version of the figures!

Some of the products on the figures in this chapter are available in different versions (straight pull, center lock etc.). For simplification there is only shown one version of the hub shell.

4.1 370 100 mm/QR non disc

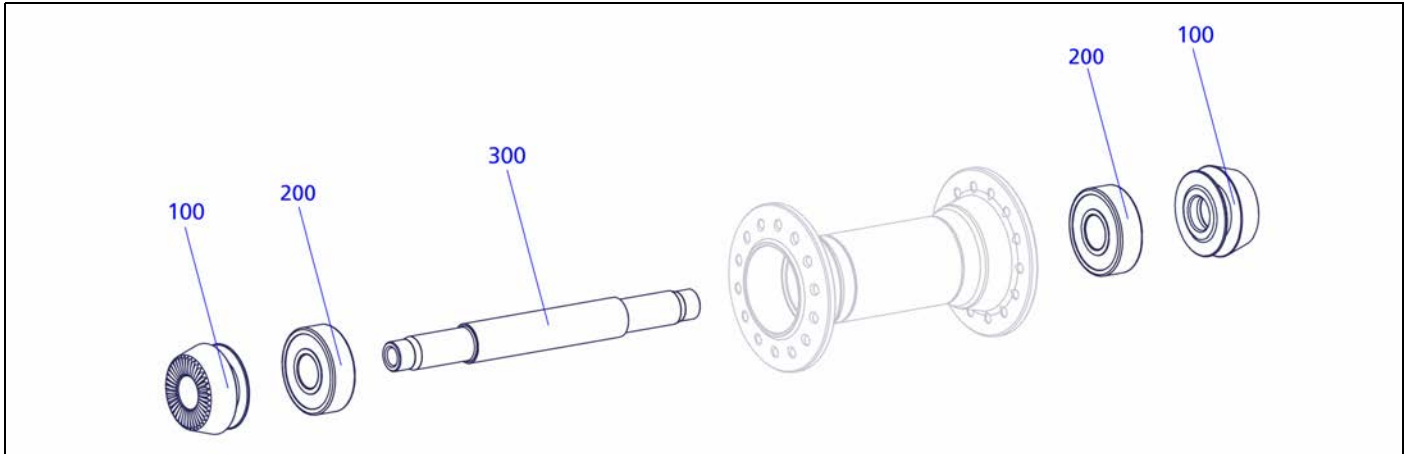

figure 4.1: 370 100 mm non disc

Pos.	Spare Part	Art. No.
100	FW adapter	HWAXXX00S4559S
200	ball bearing	HSBXXX00N1002S
300	axle	HRCXXX00N4558S

4.2 370 100 mm/QR disc brake

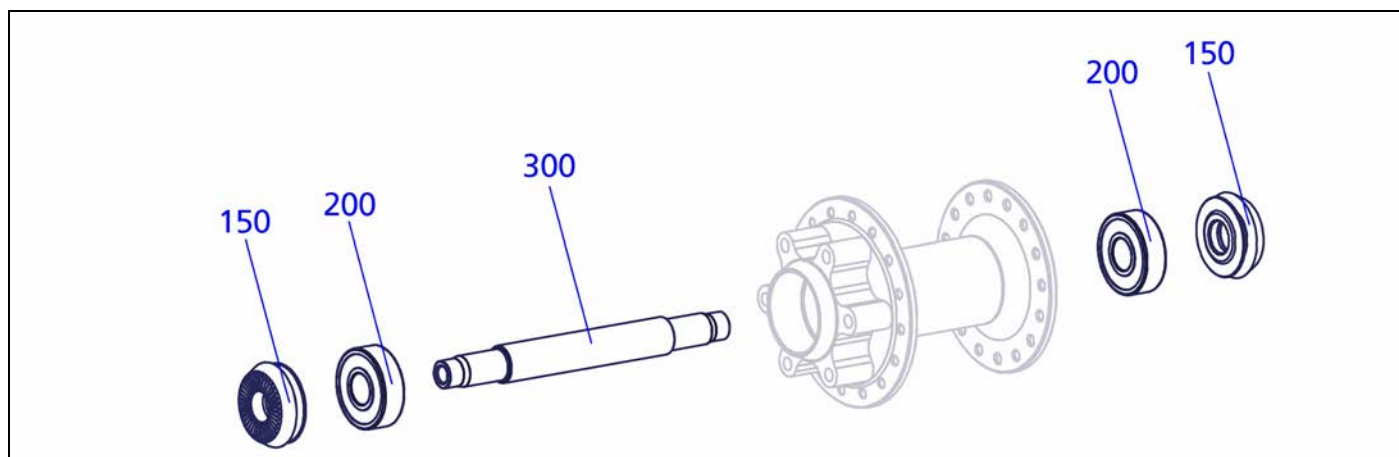

figure 4.2: 370 100 mm disc brake

Pos.	Spare Part	Art. No.
150	FW adapter	HWAXXX00S4522S
200	ball bearing	HSBXXX00N1002S
300	axle	HRCXXX00N4252S

4.3 370 100 mm/15 mm

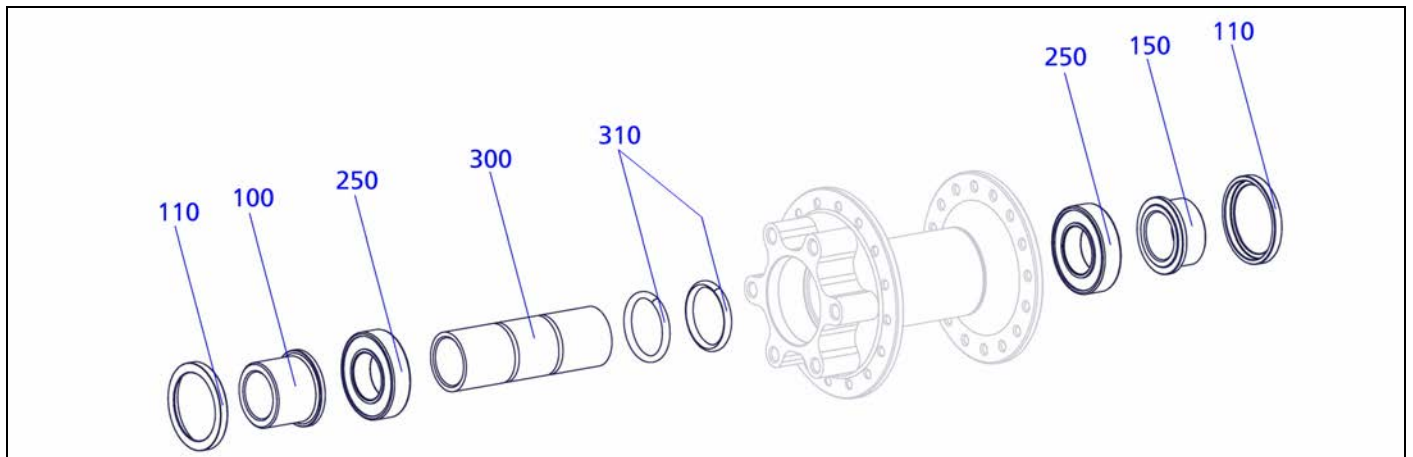

figure 4.3: 370 100 mm/15 mm disc brake

Pos.	Spare Part	Art. No.
100	adapter left	HCA00100S4601S
110	cover	HCD00100S4603S
150	adapter right	HCA00100S4602S
250	ball bearing	HSBXXX00N1468S
300	spacer	HXD00000N4600S
310	o-ring	HSOXXX00X2164S

4.4 370 110 mm/20 mm

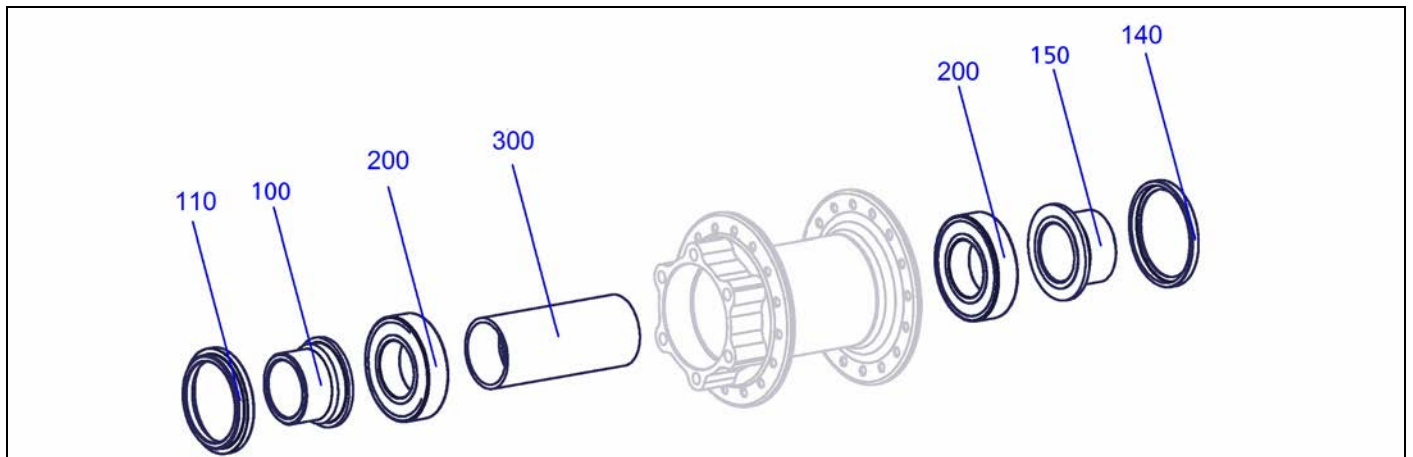

figure 4.4: 370 110 mm/20 mm disc brake

Pos.	Spare Part	Art. No.
100	adapter left	HCAXXX00S1457S
110	cover left	HCDXXX00S1458S
140	cover right	HCDXXX00S1461S
150	adapter right	HCAXXX00S1460S
200	ball bearing	HSBXXX00N1414S
300	spacer	HXDXXX00N1459S

4.5 370 130 mm/QR

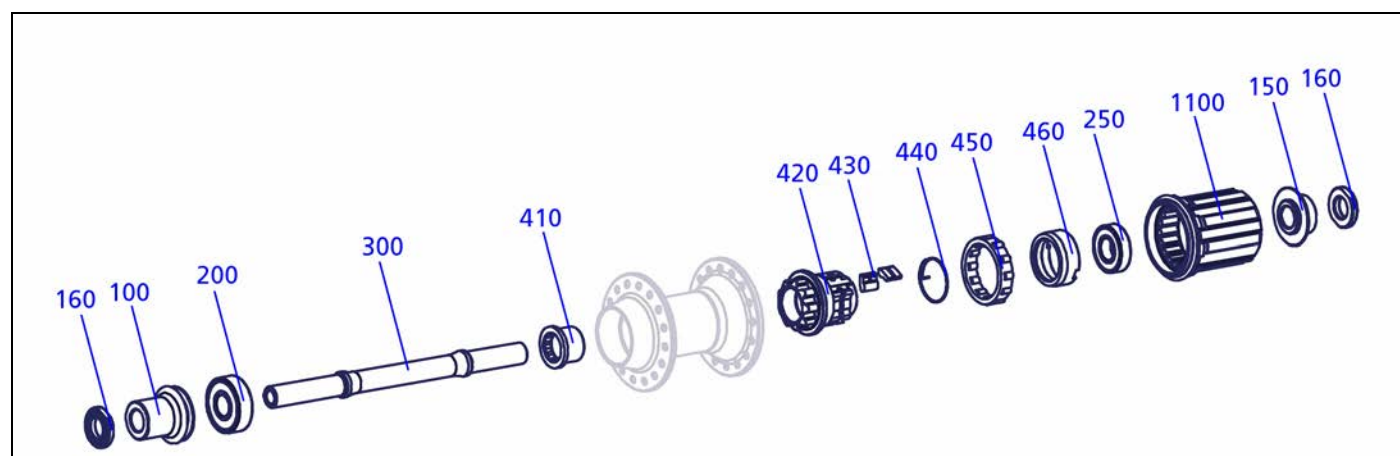

figure 4.5: 370 130 mm/QR non disc

Pos.	Spare Part	Art. No.
100	adapter left	HCAXXX00S4531S
150	adapter right 10-speed	HCAXXX00S4532S
	adapter right 11-speed	HCA00100S4368S
160	knurled disc	HCDXXX00S4081S
200	ball bearing	HSBXXX00N1002S
250	ball bearing	HSBXXX00N4085S
300	axle	HCCXXX00S4093S
410	screw fitting for pawl carrier	HCDXXX00N4077S
420	pawl carrier	HCDXXX00S4160S
430	pawl	HCDXXX00S4074S
440	pawl spring	HXDXXX00S4075S
450	needle cage kit (needle cage, 12 needles)	HWDXXX00S4089S
460	bearing shell	HCDXXX00N4076S
1100	rotor Shimano 10-speed	HWRABX00S4130S
	rotor Shimano 11-speed	HWRABX00S4366S
-	service kit ONYX/CERIT (spring, two pawls, universal grease)	HWTXXX00NSKONS

4.6 370 135 mm/QR

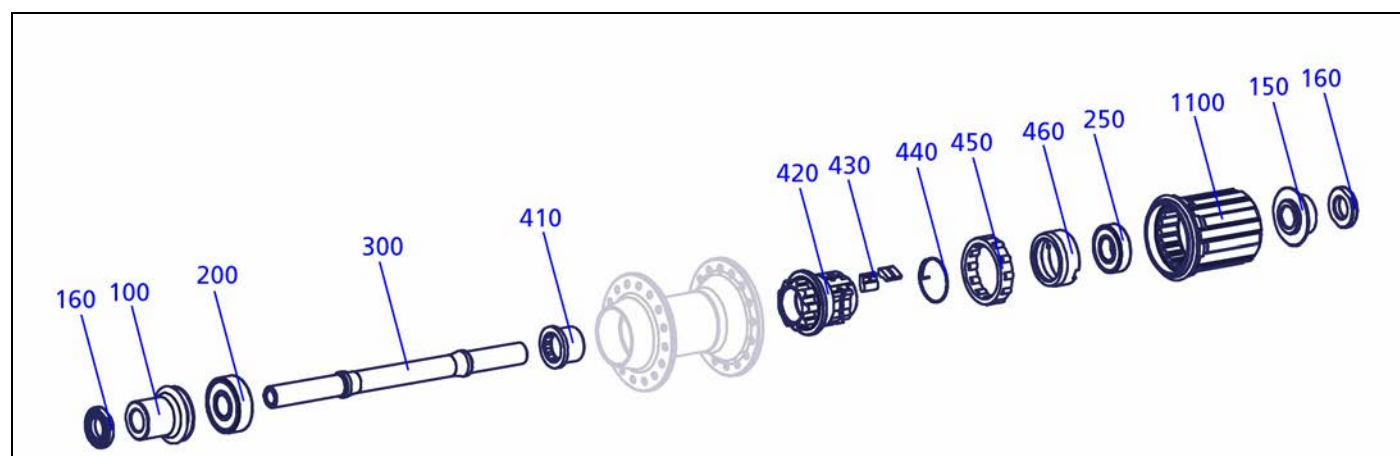

figure 4.6: 370 135 mm/QR non disc

Pos.	Spare Part	Art. No.
100	adapter left	HCAXXX00S4534S
150	adapter right 10-speed	HCAXXX00S4532S
	adapter right 11-speed	HCAXXX00S4416S
160	knurled disc	HCDXXX00S4081S
200	ball bearing	HSBXXX00N1002S
250	ball bearing	HSBXXX00N4085S
300	axle	HCCXXX00S4079S
410	screw fitting for pawl carrier	HCDXXX00N4077S
420	pawl carrier	HCDXXX00S4160S
430	pawl	HCDXXX00S4074S
440	pawl spring	HXDXXX00S4075S
450	needle cage kit (needle cage, 12 needles)	HWDXXX00S4089S
460	bearing shell	HCDXXX00N4076S
1100	rotor shimano 10-speed	HWRABX00S4130S
	rotor shimano 11-speed	HWRABX00S4403S
-	service kit ONYX/CERIT (spring, two pawls, universal grease)	HWTXXX00NSKONS

4.7 370 142 mm/12 mm disc brake

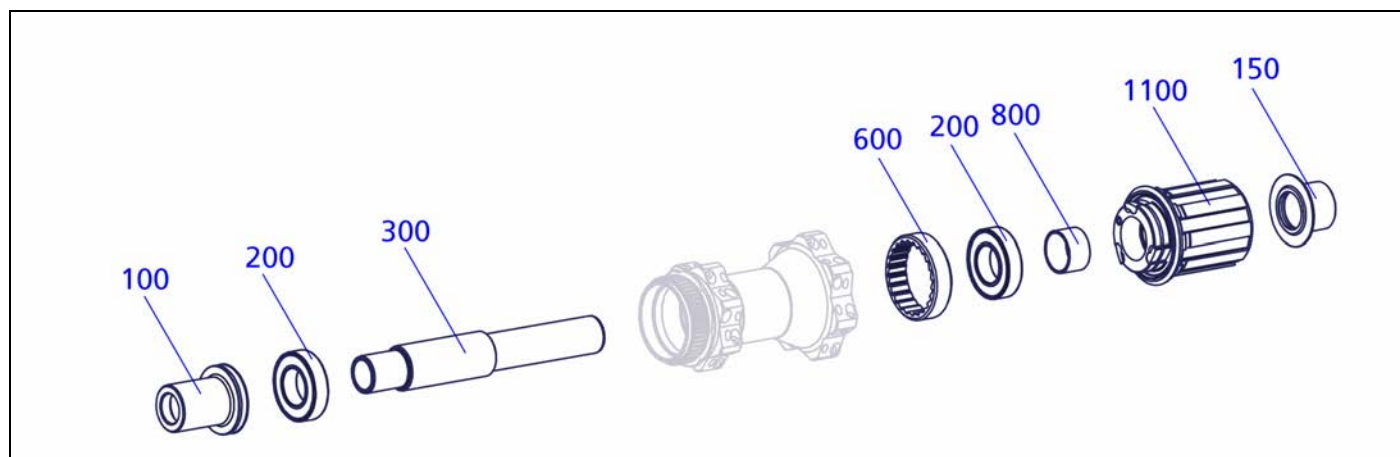

figure 4.7: 370 142 mm/12 mm disc brake

Pos.	Spare Part	Art. No.
100	adapter left	HWAXXX00S4648S
150	adapter right	HWAXXX00S4637S
200	ball bearing	HSBXXX00N1468S
300	axle	HCCXXX00N4635S
600	ring nut	HCDXXX00N4191S
800	spacer	HCDXXX00S4190S
1100	rotor	HWRABM00S4193S
-	service kit 3 pawl system	HWTXXX00NSK3PS

DT Swiss AG

Längfeldweg 101

CH - 2504 Biel/Bienne

E-mail: mail@dtswiss.com

DT Swiss, Inc.

2493 Industrial Blvd.

USA - Grand Junction, CO 81505

E-mail: info@dtswiss-us.com

DT Swiss (France) S.A.S.

Parc d'Activites de la SARREE

Route de Gourdon

F - 06620 Le Bar sur Loup

E-Mail: service.fr@dtswiss.com

DT Swiss (Asia) Ltd.

No. 26, 21st Road Industrial Park

Taichung City

E-mail: info@dtswiss-asia.com

www.dtswiss.com

Subject to technical alterations, errors and misprints excepted. All rights reserved.

© by DT Swiss AG